



REPUESTOS MOTOR MINSEL



M100



MAQUINARIA AGRICOLA
BLASCO S.L.



MOTOR TIPO M - 100 ENGINE TYPE M - 100



AVDA. SANTA POLA Nº1
ELCHE (ALICANTE) 03203
TELF. 96 661 52 44
FAX . 96 545 53 91
www.agricolablasco.com

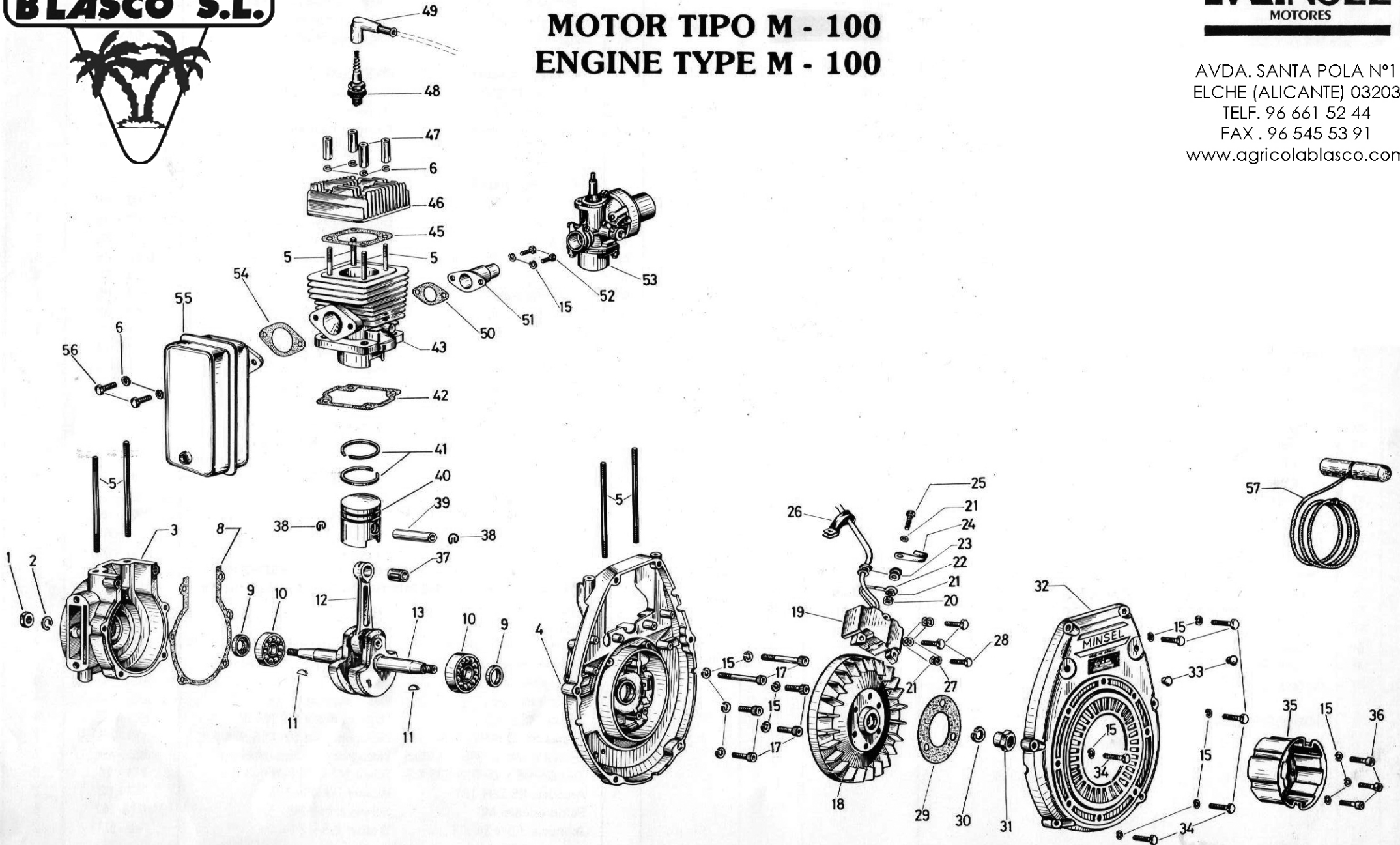



**ARRANCADOR REVERSIBLE
RECOIL STARTER**
Motor tipo: M - 100
Engine type: M - 100

Nr. No.	DENOMINACION PART NAME	REFERENC. CODE	CANT. Q'TY
1	Polea arranque — Starter pulley	1542 - 24	1
2	Arandela B6 — Washer B6 DIN 127	763 - 01	7
3	Tornillo M6 x 15 — Screw M6 x 15 DIN 912 8.8	992 - 27	3
4	Tuerca M8 — Hexagonal nut M8 DIN 934 6.8	323 - 03	1
5	Arandela Ø8,4 — Washer Ø8,4 DIN 6798	750 - 04	1
6	Arandela de freno — Thrust washer	1542 - 12	1
7	Arandela acerada — Steel washer	1542 - 13	1
8	Disco de freno — Friction plate	1542 - 07	1
9	Uña de arranque — Starter ratchet	1542 - 08	1
10	Muelle de freno — Friction spring	1542 - 10	1
11	Carrete — Reel	1542 - 03	1
12	Cuerda de arranque — Starter rope	1542 - 05	1
13	Arandela tope — Stop washer	1542 - 14	1
14	Puño de arranque — Starter handle	1541 - 70	1
15	Resorte espiral — Power spring	1542 - 04	1
16	caja de arranque — Starter case	1042 - 16	1
17	Tornillo M6 x 15 — Screw M6 x 15 DIN 912 8.8	992 - 27	4
18	Arrancador completo dcha. — Starter assembly right	1042 - 80	

